

aeroqualTM

SERIES 930

USER GUIDE



NEED HELP?



SCAN OR CLICK HERE
TO CONTACT US



Air-Met Scientific
www.airmet.com.au

Aeroqual Limited
109 Valley Road, Mount Eden
Auckland, New Zealand
t +64 9 623 3013
f +64 9 623 3012
e technical@aeroqual.com
aeroqual.com

Contents

1. Description	3
1.1. S930 Components	3
1.2. Components not supplied but required	3
2. Configuration	3
2.1. Using the Aeroqual USB to RS485 converter	3
2.2. Configuring the S930 using the PC software	4
2.2.1. Changing the Port ID	4
2.2.2. Alarms	4
2.2.3. Control	4
2.2.4. 4-20mA output scale	5
2.2.5. Upload	5
2.2.6. Download	5
3. Operation	5
3.1. Description of Outputs	5
3.2. Operation as a Relay Controller	6
3.2.1. Procedure	6
3.3. Operation as a 4-20 mA transmitter	6
3.3.1. Procedure	7
3.4. Operation as a RS485 Transmitter	8
3.4.1. Connecting via RS485	8
3.4.2. Network Settings	8
4. S930 Specifications	9
5. Gas Measurement Guidelines	9
6. Troubleshooting	10
7. Diagnostics	11
8. RS485 Protocol	11
9. Care and Maintenance	17
9.1. Disposal / Recycling	17
10. Appendix	18
10.1. Copyright	18
10.2. Software License	18
10.3. Terms and Conditions	18
10.4. Statements of Compliance	18

1. Description

The Aeroqual Series 930 Fixed Gas Monitor is designed to measure and control gas concentrations and to communicate to a variety of hardware systems.

The monitor can operate as a relay controller with user controlled set points, a 4-20 mA gas transmitter as well as communicate via RS485 on a network. They can also connect to PC data logging and networking software to allow for real-time network capability to be set up and logged data to be stored. The software can be found at our website www.aeroqual.com.

1.1. S930 Components

The following components are supplied with the S930 Fixed Gas Monitor:

- Series 930 base unit
- Temperature and Relative Humidity Sensor (Optional)
- Integrated display (Optional)
- Strobe & Siren (Optional)
- RS485 to USB converter for PC configuration (Optional)

Please check that all these components have been supplied and contact your distributor or Aeroqual at technical@aeroqual.com if any of the components are missing.

Replacement sensor heads and other accessories can be purchased separately.

Note: All sensor heads deteriorate over time. We recommend recalibration once a year and replacement every two years or when the “sensor aging” or “sensor failure” diagnostics appear. Sensors require more frequent maintenance if run continuously at site.

1.2. Components not supplied but required

- 24VDC 1A power supply for powering the Series 930

2. Configuration

The Series 930 alarm and 4-20mA output scale settings can be configured via the Fixed Monitor Configuration software. The PC software can be found on our website at www.aeroqual.com.

To configure the instruments by computer you will need an RS232/RS485 or USB/RS485 converter. There are many RS232/RS485 converters available on the market however only certain brands will function well with the Aeroqual products. Aeroqual can supply a USB/RS485 converter suitable for configuring the instruments. Please contact your account manager for more information or contact sales@aeroqual.com.

2.1. Using the Aeroqual USB to RS485 converter

The USB-RS485 converter cable provides a USB to RS485 serial interface with customised end connectors. The drivers required can be downloaded for free from www.ftdichip.com.

Note: Aeroqual S930 monitors communicate via 2 wire RS485 so the converter must be configured to RS485 2W.

USB to RS485 wiring	S930 Output
GND (Black)	GND
Data+ (A) (Orange)	RS485A
Data- (B) (Yellow)	RS485B



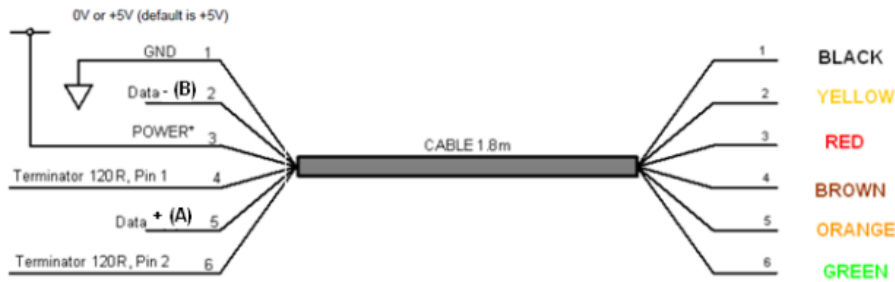

2.2. Configuring the S930 using the PC software

- Plug in and install the USB to RS485 converter into your computer
- Wire the RS485 outputs into the instrument using table above
- Install the Aeroqual Fixed Monitor Configuration PC software
- Power up the instrument
- Run the Fixed Monitor Configuration software
- Select Unit by entering the Port ID of the instrument you wish to modify and click on "Download" to download the unit's current values

Note: All new products have a default ID of 1

- Modify settings
- Click Upload to upload the settings to the instrument
- Click Exit

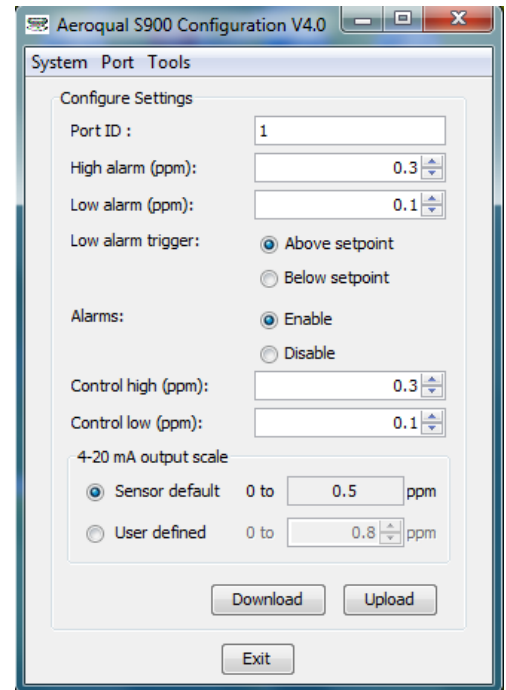

2.2.1. Changing the Port ID

Click on "Port" menu and select "Change Port ID" to change ID to your requirement in the range 1 to 255.

Note: If you are setting up a network please ensure each unit has a unique ID otherwise there will be conflicts and data loss.

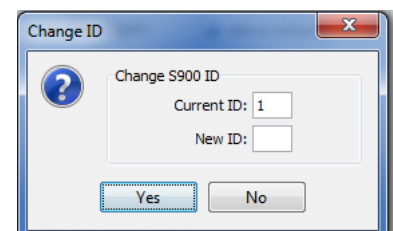

2.2.2. Alarms

High alarm and low alarm set points can be configured by entering the required activation set point on the main menu.

Note: The high alarm set point must be greater than low alarm set point

The low alarm trigger determines whether low alarm is activated when the concentration goes above or below the set point. The Alarms can be enabled or disabled by clicking "Enable" or "Disable" on the main menu.

2.2.3. Control

The control output is triggered according to the band set by the control high and control low values.

Note: Control high must be greater than control low

The action of this output is designed to enable control of an external device such as an ozone generator. The control output will be "on" when the concentration is rising in the range from below control low until it hits control high when it turns off. It remains off until the concentration falls below control low.

2.2.4. 4-20mA output scale

The 4-20mA output scale sets the gas concentration scale. Each sensor head type has a default setting but the user can modify this by clicking the user define button and entering the required value that corresponds to 20mA.

2.2.5. Upload

Clicking this button uploads the settings to the instrument.

2.2.6. Download

Clicking this button downloads the settings from the instrument. Use this function to check the settings are correct.

3. Operation

3.1. Description of Outputs

DIAG

This output is designed to enable detection of sensor faults. This is normally floating but is set to GND when the sensor fails. Thus it can be considered a "switch" which is closed when the sensor fails. This can be used to activate an alarm or relay and can also be monitored with a PLC. The output is an open collector current sink. The maximum rating of the transistor output is 24VDC at 150mA.

LoALM

This is set to GND when low alarm is activated. It is floating at other times. Use the Configuration Program to set the Low alarm set point. The output can be used to drive an alarm relay or similar. The alarm can be set to trigger above or below the set point using the configuration software. The output is an open collector current sink. The maximum rating of the transistor output is 24VDC at 150mA. If a relay coil is connected or any other inductive load to the transistor outputs, a back EMF suppression diode must be fitted across the load.

HiALM

This is set to GND when high alarm is activated. It is floating at other times. Use the Configuration Program to set the Hi alarm set point. The output can be used to drive an alarm relay or similar. The output is an open collector current sink. The maximum rating of the transistor output is 24VDC at 150mA. If a relay coil is connected or any other inductive load to the transistor outputs, a back EMF suppression diode must be fitted across the load.

CNTRL

This is set to GND when the gas concentration is rising in the range from below the Control low set point to the Control high set point at which stage, it is set to floating. It remains floating until the concentration falls below the Control low set point at which point, it is reset to ground. Use the Configuration Program to set the Control set points. This output can be used to control, for example, a gas generator or vent in a process operation. The output is an open collector current sink. The maximum rating of the transistor output is 24VDC at 150mA. If a relay coil is connected or any other inductive load to the transistor outputs, a back EMF suppression diode must be fitted across the load.

STBY

STBY is a hardware toggle switch. If it is briefly pulsed (about 50ms) to GND it puts the sensor head into Standby mode and the S930 into Sleep mode. If pulsed again to GND it will return to normal operation. This can be used to protect the sensor during process room cleaning and/or to reduce power and extend sensor life when the sensor is not needed.

3.2. Operation as a Relay Controller

The S930 has a set of integrated relay contacts which can be used to operate the instrument as a simple relay controller. The relays need to be wired into the instrument using the relevant alarm or control outputs, which are open collector current sinks. The alarm and control outputs are set to ground when activated according to their set points. The set points can be configured by computer using the Configuration PC software. It is recommended that the DIAG output is always used to alert a sensor fault condition.

3.2.1. Procedure

- Connect 24VDC power supply
- Connect alert relay/alarm to DIAG output screw connector if required
- Connect relay ground toggle to STDBY pin on the screw connector if required.
- Connect control relay to CNTL output on the screw connector if required.
- Connect relays to LoALM and/or HiALM alarm outputs on the screw connector if required
- Power on and test response.

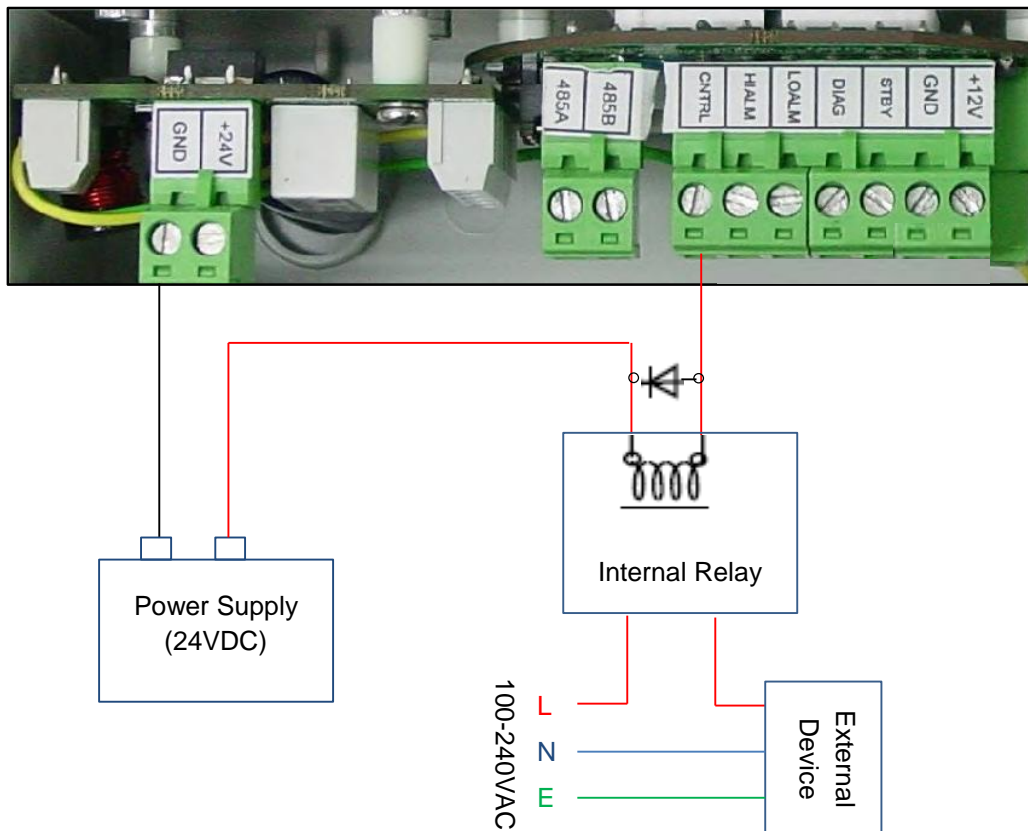

Note: HiALM, LoALM and DIAG are also transistor outputs

3.3. Operation as a 4-20 mA transmitter

The Series 930 can be connected to a PLC or current sensing device via the 4-20mA output to provide concentration information. The output is linearly proportional to concentration. The full scale (20mA) value is factory set but can also be user configured with the Configuration PC software. If the sensor fails the output will be 20mA. It is also recommended that the DIAG output is used to monitor for fault conditions.

The 4-20mA output loop is opto-isolated from the Series 930 unit and it is recommended that it be powered by a separate power supply with a voltage in the range 12-24V applied with the correct polarity. This will produce the most reliable connection method. If opto-isolation is not important then the 4-20 mA loop may be powered by the same power supply as the unit.

3.3.1. Procedure

- a. Connect the 4-20mA loop on the screw connector to the power supply and current measuring device (e.g. PLC) ensuring the polarity is correct. Please refer to the diagrams below.

Note: If the polarity is incorrect the 4-20mA output may be permanently damaged

- b. Power on the S930 and PLC
- c. Check the PLC or current sensing device to ensure data is being shown

Note: The 4-20mA outputs are located on the side of the unit as shown in the diagrams below

4-20 mA wiring diagram for Loop without opto-isolation

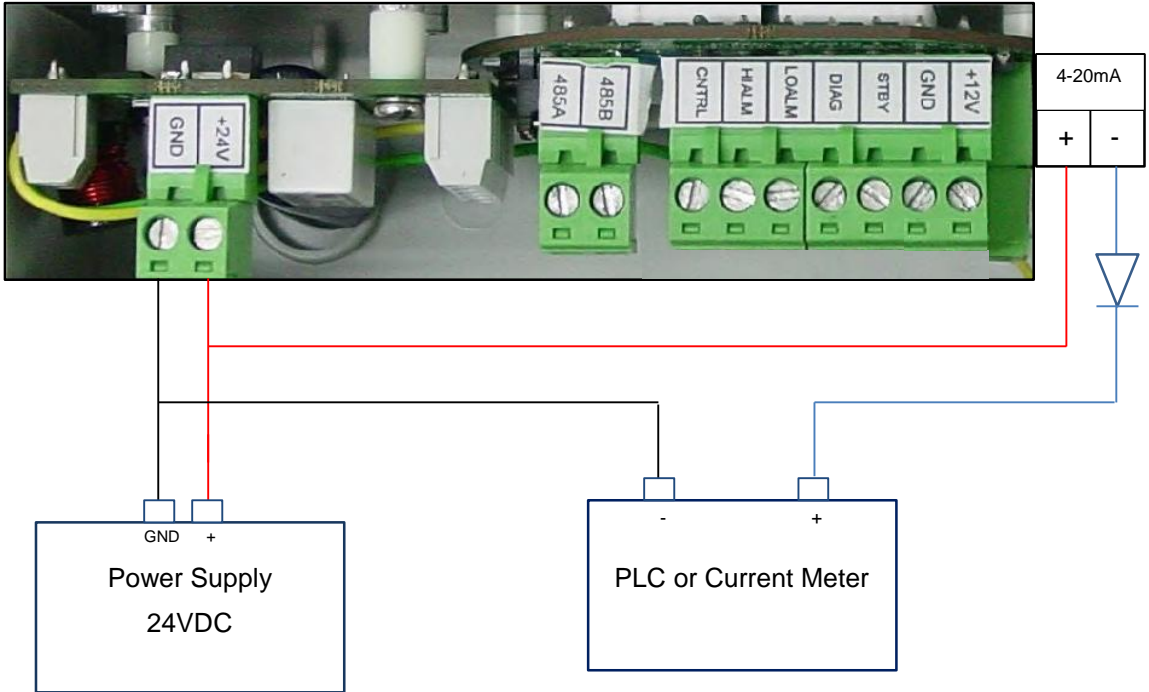

4-20 mA wiring diagram for Loop with opto-isolation

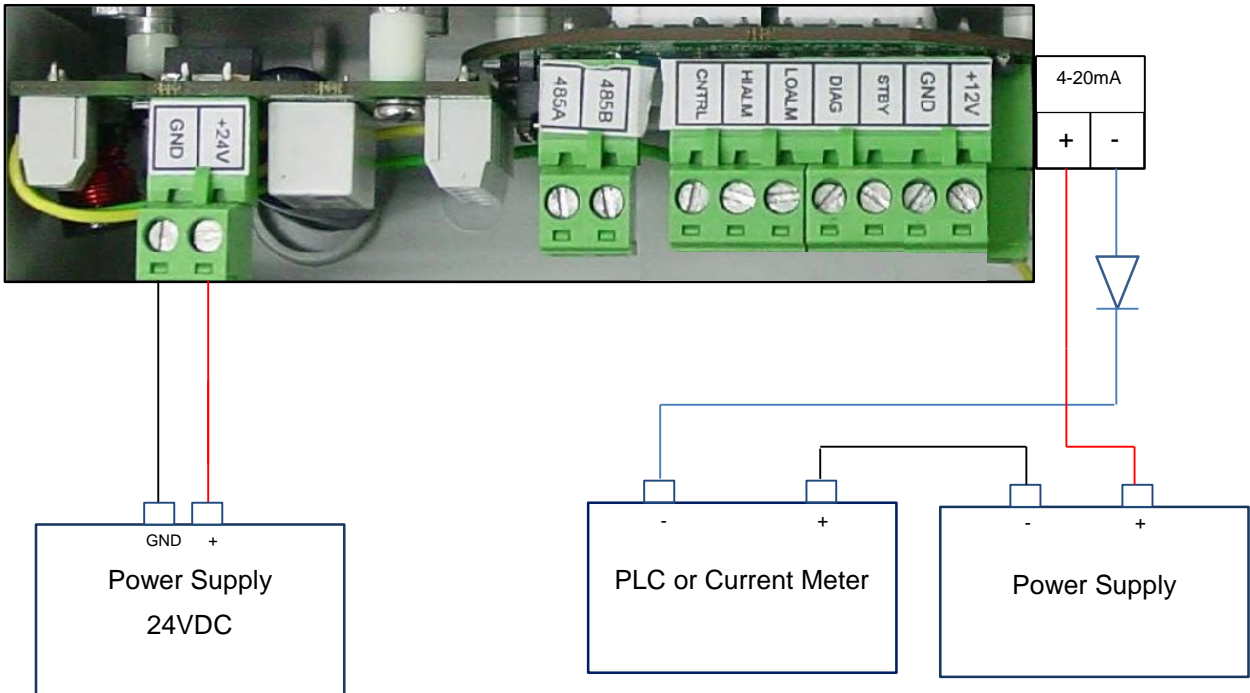

4-20 mA wiring diagram for Loop with integrated display

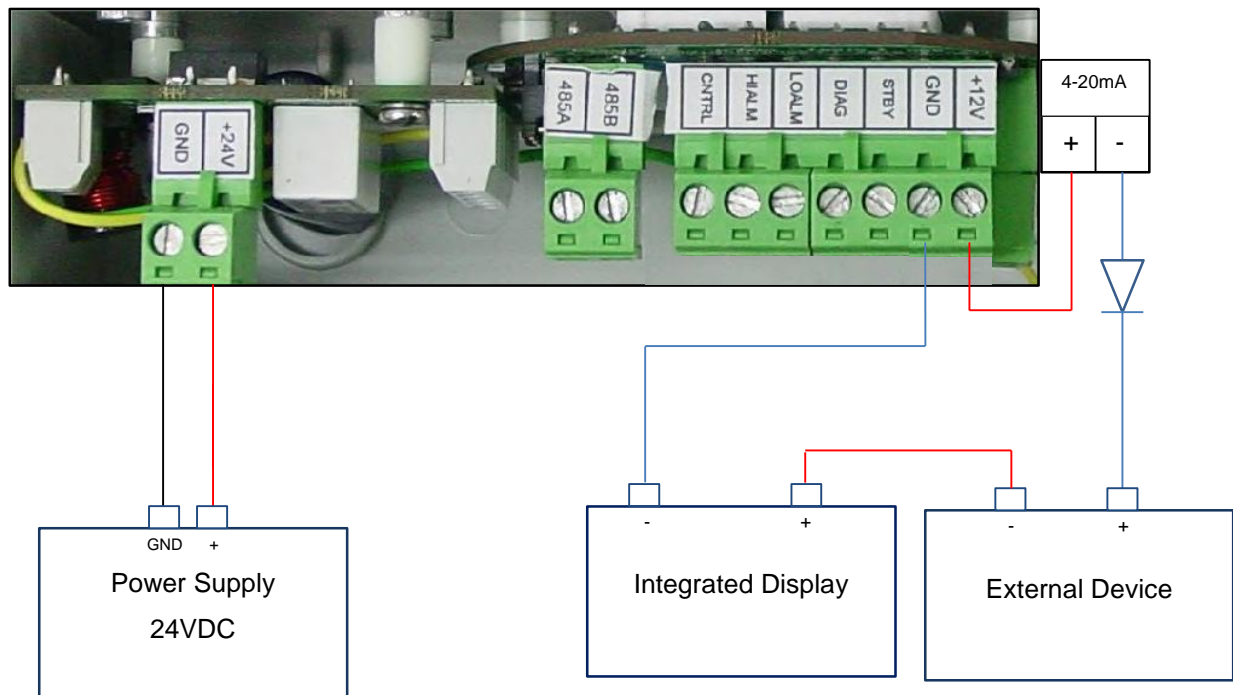

Note: The integrated display is a single ended device and therefore always needs to be located at the end of the loop.

3.4. Operation as a RS485 Transmitter

The Series 930 unit can communicate over a RS485 bus. Each monitor has an ID which can be user defined via the Configuration PC software. Up to 255 units can be networked together using the Network PC software.

Note: Both the Configuration and Network PC software can be found on our website

www.aeroqual.com

3.4.1. Connecting via RS485

- Connect a 24vDC power supply to the power input on the PCB screw connector
- Use a twisted pair cable to connect the RS485 lines on the screw connector to the RS485 hub, bus or converter
- Power up the monitor and run the communication software on your computer or PLC

3.4.2. Network Settings

If the S930 is to be used as part of a “daisy chained” RS485 network a number of settings need to be adjusted.

Jumper settings

The termination resistors need to be set correctly to ensure the network communication is stable. The jumpers JP1, JP2, JP3 are to install termination resistors on the RS485 communication lines. Remove the jumpers J1, J2, J3 for all S930 units in a chain except the last S930 unit in the network chain. If there is only one unit then set the jumpers in place. To access these jumpers remove the sensor head and unscrew the S930 base plate.

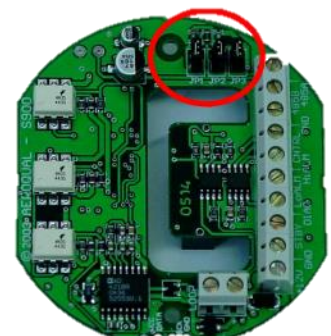

ID Settings

Monitors on the network require unique IDs so they can be distinguished on the RS485 network. The factory default ID of the units is ID 1. Therefore they will need to be changed to unique IDs. Use the Configuration PC software to change the IDs.

4. S930 Specifications

Power (user supplied)	24V DC, 500mA (range 22-26V DC)
Analogue output	4-20mA (opto-isolated), 12-24V
External signal type	Transistor output (150mA max)
External signals (4)	Low Alarm High Alarm Control Diagnostics
LED Display	Optional
Inputs	Standby toggle
Communication	RS485 (Aeroqual proprietary protocol)
Jumpers	J1, J2, J3 termination resistors
Connectors	Screw
ID	1 (Default) User configurable from 1 to 255
Alarm set points (2)	User configurable
Control set point	User configurable
Removable/replaceable sensor head	Yes
Sampling method	Active sampling via internal sensor fan
Temperature & humidity sensor (Optional)	Range -40°C to 124°C (-40°F to 255°F) Range 0 to 100% RH
Configuration software	PC Configuration Software
Data logging & networking software	PC Data Logging & Networking Software
Enclosure casing	Fibre reinforced polycarbonate IP41 & NEMA 2 equivalent
Enclosure size	180 x 110 x 90 (mm); 7 1/8 x 4 3/4 x 3 1/2 (in)
Weight	< 850 g; < 30 oz
Approvals	Part 15 of FCC Rules EN 50082-1: 1997 EN 50081-1: 1992

5. Gas Measurement Guidelines

The S930 should be installed at a location that is free from contaminants that might affect the performance of the sensor head. Please contact technical@aeroqual.com for assistance with specific chemicals that you believe may adversely affect the supplied sensor. In general the S930 should **never** be exposed to:

- Steam, fumes, water or chemical spray
- Aggressive solvents
- High condensing humidity
- Cooking vapours/aromas
- Paint fumes
- High levels of dust

Ensure that the controller is protected from excessive water splashing, dust, vibration, excessive heat or cold, excessive swings in humidity and gas concentrations outside the range of the specific sensor head.

6. Troubleshooting

Fault Description	Possible Cause	Remedy
No Power	Power connection broken Power supply failure S930 damaged	Reconnect power cable Replace 24V power supply Replace unit
RS485 communications unstable	RS485/RS232 adaptor faulty Connections broken ID incorrect Noise on cable Sensor head not fitted correctly	Reconfigure/replace adaptor Reconnect leads Check ID Use shielded twisted pair cable Insert head correctly
4-20mA output failure	30V input exceeded	Replace S930
Network unstable	ID conflict Noise on cable Jumpers set incorrectly 930 units too close together	Modify IDs so that no S930 units share the same ID Use shielded twisted pair cable Set jumpers correctly The cables between the S930 units should be a minimum of 30 cm in length
If connected to a display:		
Display shows -1	Over-range (>20mA) reverse loop current	Loop polarity is incorrect. Reverse the polarity. Incorrect loop polarity can cause irreversible damage to the 930 unit
Display shows 1	Over-range loop current (>20 mA)	Reduce loop current
Display shows -.125	4-20mA loop not powered	Power loop. The display requires the loop to be powered to read correctly
Display oscillated between min and max	Sensor head not fitted correctly	Insert sensor correctly
Sensor failure when new sensor connected	Insufficient warm-up Air contaminated Sensor damaged	Run the sensor for 24-48 hours Move the sensor to cleaner environment and check reading Replace sensor
Sensor showing high baseline reading under zero gas conditions	Background gas level higher than normal Interference gas present Sensor zero drift Sensor damaged	Move sensor to clean environment and recheck baseline Move sensor to clean environment and recheck baseline Rezero sensor in a clean, stable environment Replace sensor
Sensor showing higher than expected reading in the presence of sensor gas	Zero calibration incorrect Span calibration incorrect Interference gas present Sensor calibration lost	Zero calibrate sensor Span calibrate sensor Move sensor to clean environment and check reading upon exposure to know concentration of gas Replace sensor

Sensor showing lower than expected reading in the presence of sensor gas	Zero calibration incorrect Span calibration incorrect Sensor inlet contaminated Interference gas present Gas reactive and decomposing before detection Sensor calibration lost	Zero calibrate sensor Span calibrate sensor Clean sensor inlet filter and mesh Move sensor to clean environment and check reading upon exposure to know concentration of gas Move the monitor closer to the source of the gas Replace sensor
Sensor output noisy	S930 power supply unregulated Local air flow too high Environmental conditions fluctuating	Install regulated power supply Reduce air flow Reduce fluctuations

7. Diagnostics

The S930 has inbuilt diagnostics to detect sensor faults. If the sensor fails it can be easily replaced by removing and installing a new sensor head. The failed sensor can be sent back to Aeroqual for replacement or disposal.

The fault conditions are explained in the below table:

Fault Description	DIAG output	4-20mA output	RS485 output
No fault	Floating	Valid gas reading	Valid gas reading Status 1 = 0x00
Sensor failure	GND	20mA	Last valid gas reading Status 1 = 0x01
Sensor aging	GND	20mA	Last valid gas reading Status 1 = 0x02
Sensor not fitted correctly	GND	Oscillated between 4 and 20mA	No reply

8. RS485 Protocol

The S930 network system is based on industrial protocol RS485. This command protocol is specified by Aeroqual Limited. Copyright reserved 2004.

The network communication is in master-slave mode, which means that a PC or other device will be the network master. All information is requested by the network master. Otherwise no information is sent out by the S930 network units.

Section 1

General description of the communication commands (for command details and data representations please refer section 4):

01. Information request command to S930. The basic format is a 5 bytes data stream:

BASE, COMMAND, NETWORK_ID, OTHERS, CHECKSUM

- * BASE - information request data stream header
- * COMMAND - 1 byte network unit action command
- * NETWORK_ID - 1 byte 930 network ID.
- * OTHERS - may used to extend functions later, it can be left as empty for now
- * CHECKSUM - makes the data stream total sum byte value to zero.

That's tow's complement of the total sum of the data stream, except CHECKSUM byte.

02. 930 unit basic reply command format will be a 15 bytes stream (see section 2 for details):

Index	0	1	2	3 - 6	7 - 10	11	12	13	14					
	SENSOR, COMMAND, NETWORK_ID, DATA1(4 bytes), DATA2(4 bytes), RESERVED, STATUS1, STATUS2, CHECKSUM													

Section 2

S930 Network ID specified commands. These commands generate a response by a specified S930 unit.

Every command needs a corresponding reply.

01. Gas Data request command. The command asks for the gas data that a specific S930 unit currently holds.

The S930 unit responds with an gas value. The gas data validity depends on the DATA_UNVALID bit of STATUS1 flag (please see Section 4 for details).

Command: BASE, GAS_CONC_DATA, NETWORK_ID, EMPTY, CHECKSUM

Reply: SENSOR, GAS_CONC_DATA, NETWORK_ID, DATA1, TEMP, RH, RESERVED, STATUS1, STATUS2, CHECKSUM

* DATA1 - 4 bytes IEEE754 floating point data, measured gas value, if DATA_UNVALID bit of STATUS1 flag is 1 then it will be last measured value, otherwise it's new measured value.

* TEMP - 2 bytes unsigned int value, its actual value equals the int value divided by 10 (TEMP/10) for its real temperature value of S930 unit

* RH - 2 bytes unsigned int value, its actual value equals the int value divided by 10 (RH/10) for its real relative humidity value of 930 unit

* For 930 the field TEMP and RH will be always zero for Version 1.5 and later.

* However, for S930 version 1.4 and earlier can't use this command to request temperature and humidity.

02. Standby command. The S930 unit will set its sensor head to standby state.

The 930 will set STANDBY bit of STATUS2 to 1 indicating it is in standby mode.

When the standby state has been terminated, it will reset STANDBY bit of STATUS2 to 0.

Command: BASE, STANDBY, NETWORK_ID, EMPTY, CHECKSUM

Reply: SENSOR, STANDBY, NETWORK_ID, DATA1, DATA2, RESERVED, STATUS1, STATUS2, CHECKSUM

* DATA1 and DATA2 - no meanings.

* The reply just confirms that it performed action, to find it check status bit.

03. Specific 930 reset command. The command will reset the 930 at any time.
 Command: BASE, RESET, NETWORK_ID, EMPTY, CHECKSUM
 Reply: SENSOR, RESET, NETWORK_ID, DATA1, DATA2, RESERVED, STATUS1, STATUS2, CHECKSUM
 * DATA1 and DATA2 - no meanings.
 * RESET - 1 byte reset command, see section 4 for details.
04. Specific 930 unit connected sensor head version number request command and reply. PC or other devices can request sensor head version information through 930 unit.
 Command: BASE, SENSOR_VERSION, NETWORK_ID, EMPTY, CHECKSUM
 Reply: SENSOR, SENSOR_VERSION, NETWORK_ID, VERSION_NUM, DISPLAY_TYPE, NAME_LENGTH, SENSOR_NAME, RESERVED, CHECKSUM
 * VERSION_NUM - 1 byte, the version number of sensor head plugged in the 930 unit
 * DISPLAY_TYPE - 1 byte, the decimal value display type, different gas sensor head are different, see section 3 for details
 * NAME_LENGTH - 1 byte, the sensor head name length.
 * SENSOR_NAME - 7 bytes max, valid length depends on NAME_LENGTH value, the sensor head name ASCII code that connected to 930 unit,
05. Modify 930 unit network ID command that can change current 930 unit network ID.
 Command: BASE, CHANGE_NETWORK_ID, OLD_ID, NEW_ID, CHECKSUM
 Reply: SENSOR, CHANGE_NETWORK_ID, NEW_ID, DATA1, DATA2, RESERVED, STATUS1, STATUS2, CHECKSUM
 * CHANGE_NETWORK_ID - 1 byte command, see section 3 for details.
 * OLD_ID - the 930 unit old network ID.
 * NEW_ID - the 930 unit new network ID
06. Specific 930 connected sensor gas unit ppm to mg/m3 convert factor and analog current max output scale factor value request command.
 Command: BASE, FACTOR_REQUEST, NETWORK_ID, EMPTY, CHECKSUM
 Reply: SENSOR, FACTOR_REQUEST, NETWORK_ID, DATA1, DATA2, RESERVED, STATUS1, STATUS2, CHECKSUM
 * DATA1 - 4 bytes, gas unit ppm to mg/m3 convert factor floating point value
 * DATA2 - 4 bytes, default 930 current output max scale factor floating point value
07. 930 unit configuration settings upload command, which sets the 930 unit alarm 1, alarm 2, defined output scale and alarm enable settings. Total 25 bytes data stream.
 Command: BASE, PARAMETERS_UPLOAD, NETWORK_ID, EMPTY, CHECKSUM
 Parameters: BASE, PARAMETERS_UPLOAD, NETWORK_ID, ALARM1, ALARM2, DEFINED_SCALE, CONTROL_HIGH, CONTROL_LOW, ALARM_STATUS, CHECKSUM
 Reply: SENSOR, PARAMETERS_UPLOAD, DATA1, DATA2, RESERVED, STATUS1, STATUS2, CHECKSUM
 * ALARM1 - 4 bytes alarm level 1 set point value, see section 4 for its data representation.

- * ALARM2 - 4 bytes alarm level 2 set point value, see section 4 for its data representation.
- * DEFINED_SCALE - 4 bytes user defined max output scale value.
- * CONTROL_HIGH - 4 bytes control high set point value see section 4 for its data representation.
- * CONTROL_LOW - 4 bytes control low set point value see section 4 for its data representation.
- * ALARM_STATUS - 1 byte alarm state settings, see section 3 for details.
- * Reply just used for confirm uploading successfully, DATA1 and DATA2 no real meanings.

08. 930 unit configure settings download command, total 25 bytes stream.

Command: BASE, PARAMETERS_DOWNLOAD, NETWORK_ID, EMPTY, CHECKSUM

Reply: SENSOR, PARAMETERS_DOWNLOAD, NETWORK_ID, ALARM1, ALARM2, DEFINED_SCALE, CONTROL_HIGH, CONTROL_LOW, ALARM_STATUS, CHECKSUM

- * ALARM1 - 4 bytes alarm 1 set point value, see section 4 for its data representation
- * ALARM2 - 4 bytes alarm 2 set point value, see section 4 for its data representation
- * DEFINED_SCALE - 4 bytes user defined max output current output value
- * CONTROL_HIGH - 4 bytes control high set point value see section 4 for its data representation
- * CONTROL_LOW - 4 bytes control low set point value see section 4 for its data representation
- * ALARM_STATUS - 1 byte alarm state settings, see section 4 for details

09. Specific 930 base unit version number request command and reply. PC or other devices can request the base unit version information.

Command: BASE, BASE_VERSION, NETWORK_ID, EMPTY, CHECKSUM

Reply: SENSOR, BASE_VERSION, NETWORK_ID, VERSION_NUM, SENSOR_COUNT, RESERVED, RESERVED, RESERVED, RESERVED, RESERVED, RESERVED, RESERVED, CHECKSUM

- * VERSION_NUM - 1 byte, the version number of the 930 unit
- * SENSOR_COUNT - 1 byte, actually used to specify its 930
 - if it's 0x01, that is 930 no temperature and humidity sensor connected,
 - if it's 0x03, that is 930 there is a temperature and humidity sensor connected.

10. Temperature and relative humidity data request command. The command asks for the temperature and humidity data that a specific 930 unit currently holds. The 930 unit responds with two values respectively.

Command: BASE, TEMP_RH_DATA, NETWORK_ID, EMPTY, CHECKSUM

Reply: SENSOR, TEMP_RH_DATA, NETWORK_ID, TEMP, RH, RESERVED, STATUS1, STATUS2, CHECKSUM

- * TEMP - 4 bytes IEEE754 floating point data, measured temperature value of 930 unit,
- * RH - 4 bytes IEEE754 floating point data, measured relative humidity value of 930 unit
- * For 930 the command will be no reply at all.

Section 3

Broadcast commands are a set of special commands of the network system. Every unit that receives the commands on the network performs the action. They are not ID specific, BROADCAST command indicator can be considered as NETWORK_ID. These commands send out by network master and that don't need reply at all.

* BROADCAST is a 1 byte special 930 ID that is zero *

01. Broadcast 930 standing by command, this command will set all sensor head that connected to the network go to stand by state. The command generates no reply. To check whether a 900 unit has performed the command, the network master should check STATUS2's STAND_BY bit.

BASE, STANDBY, BROADCAST, EMPTY, CHECKSUM

* BROADCAST - 1 byte broad cast indicator, see section 3 for its value

02. Broadcast 930 reset command; it will reset whole network sensor heads that connected to. The command generates no reply. To check whether a 900 unit has performed the command, the network master should check STATUS2's STAND_BY bit.

BASE, RESET, BROADCAST, EMPTY, CHECKSUM

* BROADCAST - 1 byte broad cast indicator, see section 3 for its value

Section 4

Protocol commands value and descriptions:

BASE = 0x55 command header used for network master to 930

SENSOR = 0xAA reply header used for 930 to network master

STANDBY = 0xFD command used to set sensor head standing by mode

RESET = 0x07 command to reset sensor head to normal working state

GAS_CONC_DATA = 0x10 command to request/report measured gas concentration value

TEMP_RH_DATA = 0x20 command to request temperature and humidity values

BASE_VERSION = 0xF9 command to request/report 930 base unit version number

SENSOR_VERSION = 0xFB command to request/report sensor head version number

FACTOR_REQUEST = 0x2A command to request/report sensor head concentration ppm to mg/m³ conversion factor and max current output scale factor

BROADCAST = 0x00 broadcast command indicator, like a special 930 ID reserved for information broadcast

PARAMETERS_UPLOAD = 0x19 command to upload configure settings to 930

PARAMETERS_DOWNLOAD = 0x18 command to download configure settings from 930

EMPTY = 0x00 no meanings at all, reserved space

RESERVED can be any value, not any meanings at all

CHECKSUM data stream check sum used to verify the command data stream information lost or noise. It makes the data stream total sum to zero.

NETWORK_ID range: 0x00 -- 0xFF, 0x00 is reserved for broadcast command. 0x01 will be the default ID when 930 has been programmed.

STATUS1	(1 Byte)	
SensorStatus0	b0 \	b1=0, b0=0, sensor is normal,
SensorStatus1	b1 /	b1=0, b0=1, sensor failure no gas reporting b1=1, b0=0, means sensor aging,
FAN_STATUS	b2	reserved
UNIT_UNSTABLE_FLAG	b3	sensor head is at setting up stage not stable yet
RESERVED	b4	reserved
RESERVED	b5	reserved
SensorResetFlag	b6	sensor head is doing reset
DATA_UNVALID	b7	the data is not valid data, maybe last reported reading

STATUS2	(1 Byte)	not used now, reserved for further developing
RESERVED	b0	reserved
RESERVED	b1	reserved
RESERVED	b2	reserved
RESERVED	b3	reserved
STANDBY	b4 = 1,	sensor head in stand by mode
	b4 = 0,	sensor head in normal working mode
RESERVED	b5	reserved
RESERVED	b6	reserved
RESERVED	b7	reserved

ALARM_STATUS (1 Byte) used for alarm status setting

Alarm_Enable	b0 = 0,	930 alarm enabled, b0 = 1, 930 alarm disabled
Alarm2_Triger	b1 = 0,	930 alarm 2 triggered when reading exceed alarm 2
	b1 = 1,	930 alarm 2 rigged when reading below alarm 2
Define_Ouput_Scale	b2 = 0,	use sensor head default current output value
	b2 = 1,	user defined current output value
RESERVED	b3	reserved
RESERVED	b4	reserved
RESERVED	b5	reserved
RESERVED	b6	reserved
RESERVED	b7	reserved

The following data values use IEEE754 32 bits floating point little endian representation.

These data are: DATA1, DATA2, ALARM1, ALARM2, DEFINED_SCALE, CONTROL_HIGH, CONTROL_LOW.

Section 5

Data transfer mechanism

1. Floating point data (4 bytes) send sequence is low byte first, high byte last, such as section 4's data DATA1, ALARM1, ALARM2 etc.
2. Broadcast command - when network master broadcast a command to RS485 bus, every unit connected to the bus has to perform the action immediately without reply. Whether the command has been performed or not can be tested using a specific sensor command to poll an individual unit. If some sensor heads do not perform the action the network master needs to rebroadcast the command again.
3. Specific unit sensor measured gas concentration request. Once a sensor head measures a new concentration it will set STATUS1 b7 to zero indicating the value is valid. However, when the new data has been sent out the STATUS1 b7 DATA_UNVALID bit will set to 1 indicating the data not valid.
4. Timing issue (VERY IMPOTANT): The master request command frequency can't be less than 1 second per command; otherwise, the network will be unstable.

Section 6

RS485 communication port settings:

Baud rate:	4800
Data bits:	8
Stop bits:	1
Parity:	none
Flow control:	none

9. Care and Maintenance

Your Aeroqual Monitor is a product of superior design and quality and should be treated with care. When using your Aeroqual Monitor:

- Keep it and all its parts and accessories out of the reach of small children.
- Keep it dry. Avoid water and/or condensation as humidity and liquids may damage sensitive electronics and the Li battery.
- Do not use or store in dusty, dirty areas.
- Do not store the monitor in temperatures below 10°C or above 35°C.
- This unit is designed for use at temperatures between -5°C and +45°C however please consult recommended operating temperature for the sensor head which may be different. Avoid sudden changes in temperature which may cause condensation that can damage the electronics.
- Do not attempt to open. Non-expert handling of the device may cause damage.
- Do not drop, knock or shake as this could lead to internal damage.
- Do not use harsh chemicals, cleaning solvents or strong detergents for cleaning. Wipe with a soft cloth slightly dampened with a mild soap-and-water solution

9.1. Disposal / Recycling

Please note that this is an electronic product and disposal should be in line with your local or country legislation. The plastic casing of the product is made from a Polycarbonate / ABS blended material (PC + ABS) and is marked accordingly.

10. Appendix

10.1. Copyright

Copyright Aeroqual Limited. All rights reserved. Reproduction, transfer, distribution or storage of part or all of the contents of this document in any form without the prior written permission of Aeroqual Limited is prohibited.

“Aeroqual” is a registered trademark of Aeroqual Limited. Other product and company names mentioned herein may also be trademarks or trade names.

Aeroqual operates a policy of continuous development. Aeroqual re-serves the right to make changes and improvements to any of the products described in this document without prior notice.

Under no circumstances shall Aeroqual be responsible for any loss of data or income or any special, incidental, consequential or indirect damages howsoever caused.

The contents of this document are provided "as is". Except as required by applicable law, no warranties of any kind, either express or implied, including, but not limited to, the implied warranties of merchantability and fitness for a particular purpose, are made in relation to the accuracy, reliability or contents of this document.

Aeroqual reserves the right to revise this document or withdraw it at any time without prior notice. The availability of particular products may vary by region. Please check with the Aeroqual dealer nearest to you.

10.2. Software License

Aeroqual will retain ownership of all intellectual property in the Fixed Monitor Software. The buyer acknowledges that they are granted a perpetual, non-exclusive, non-transferable license for the right to use the Software for the buyer's exclusive use and only in conjunction with Aeroqual Products (Intended use). The buyer will strictly adhere to the Intended Use of the Software and will not translate, adapt, reverse compile or other-wise alter the Software. The buyer undertakes not to disclose, assign, sell, rent, lend, sub license or otherwise transfer the Software.

10.3. Terms and Conditions

This product is warranted according to Aeroqual Ltd.'s Terms of Trade. For further warranty information, please refer to the standard Product Warranty Policy as published on the Aeroqual website at www.aeroqual.com.

10.4. Statements of Compliance

1. The Aeroqual Series 930 Fixed Monitor complies with EN 50082-1: 1997
2. The Aeroqual Series 900 Fixed Monitor complies with EN 50081-1: 1992
3. The Aeroqual Series 900 Fixed Monitor complies with Part 15 of the FCC Rules. Operation is subject to the following two conditions:
 - These devices may not cause harmful interference, and
 - These devices must accept any interference received, including interference that may cause undesired operation.

NOTE: This equipment has been tested and found to comply with the limits for a Class B digital device, pursuant to Part 15 of the FCC Rules. These limits are designed to provide reasonable protection against harmful interference in a residential installation. This equipment generates, uses and can radiate radio frequency energy and, if not installed and used in accordance with the instructions, may cause harmful interference to radio communications. However, there is no

guarantee that interference will not occur in a particular installation. If this equipment does cause harmful interference to radio or television reception, which can be determined by turning the equipment off and on, the user is encouraged to try to correct the interference by one or more of the following measures:

- Reorient or relocate the receiving antenna.
- Increase the separation between the equipment and receiver.
- Connect the equipment into an outlet on a circuit different from that to which the receiver is connected.
- Consult the dealer or an experienced radio/TV technician for help.

