

Operating Manual

Infrared Point Gas Detector GD10-P00



Note

This manual must be carefully read by those who have or will have the responsibility for the operation or maintenance of this product. The product may not perform as designed if it is not used and maintained in accordance with the manufacturer's instructions.

The warranties made by Simtronics with respect to the product are voided if the product is not used and maintained as described in this manual.

Please read the general warnings in chapter 7.

© Simtronics AS, all rights reserved.

Table of contents

1. PRODUCT DESCRIPTION	4
2. TECHNICAL SPECIFICATIONS.....	5
3. INSTALLATION.....	7
3.1. Positioning.....	7
3.2. Fixing.....	7
3.3. Weather protection	8
3.4. Duct or pipe mounting.....	9
3.5. External cable.....	11
3.6. Electrical connection	12
4. COMMISSIONING.....	13
4.1. Visual inspection	13
4.2. Power up.....	13
4.3. Checking system functions.....	13
5. OPERATION.....	14
5.1. Analogue Output Protocol.....	14
5.2. HART® Interface	14
6. MAINTENANCE	20
6.1. Cleaning of optical lens/mirror	20
6.2. Function test.....	20
6.3. Calibration test.....	21
6.4. Re-zero	21
6.5. Fault finding.....	23
7. WARNINGS.....	24
7.1. Ownership and confidentiality.....	24
7.2. Liability.....	24
8. WARRANTY	25
9. CERTIFICATIONS AND STANDARDS	25
9.1. Standards.....	25
9.2. Approvals.....	25
9.3. Marking	26
9.4. Explanation of product coding.....	27
10. ACCESSORIES AND SPARE PARTS	28
APPENDIX 1 #-codes for generic HART®GD10	30
CONTACT DETAILS.....	32

1. PRODUCT DESCRIPTION

The GD10P has been designed with features that provide an effective response to the detection of gas hazards in a wide range of industrial environments from boiler plant rooms to offshore petrochemical installations.

These infrared gas detectors differ from all other models, because they utilise silicon based solid-state infrared sources. The complete opto-mechanical design and construction is so stable that an ultra-fast speed of response can be achieved whilst providing unparalleled service life and detector stability, thus saving on maintenance and service costs.

We offer the longest combined detector and IR source warranty on the market.

For retrofit applications, a bridge interface is available allowing the detector to be connected directly to catalytic systems, using the existing cabling and control modules.

Supplied with worldwide performance (CSA / CENELEC) and hazardous area approvals.

Suitable for use in SIL 2 and SIL 3 systems.

Compared with catalytic sensors, the GD10P has the following advantages:

- Presence of oxygen is not required for correct measurement, which makes the GD10P suitable even in an inert gas atmosphere.
- No possibility of poisoning of the detector since no chemical reaction occurs, i.e. silicon vapours and H₂S have no effect on the detector or the measurement.
- The gas flow rate has no influence on accuracy.
- There are no saturation effects which could lead to false measurements. Thus, the detector is capable of measuring gas concentrations up to 100% vol.
- The detector has a continuous self-test function, and reports dirty optics and fault conditions to the control system.
- Total system costs can be dramatically reduced with the GD10P:
- High reliability results in low test frequency and no calibration costs.

2. TECHNICAL SPECIFICATIONS

Version: 0-100%LEL Methane, 5 sec. response time.
(Specification for other types on request)

GENERAL

Detection method	IR-absorption, dual wavelength, dual path
IR-Source	Solid state IR source, 50Hz flash
Gases detected	Detector versions for several hydrocarbons as well as CO ₂ .
Self-test	Continuous
Calibration	Factory set, no field recalibration

PERFORMANCE

Lifetime stability *)	±5% of full scale (FS) reading
Accuracy *)	±3% FS between 0-50 % reading ±5% FS between 50-100 % reading
Response time	T20 = 1 sec. (Optional 0.3 sec) T50 = 2.5 sec. (Optional 0.7 sec) T90 = 6 sec. (Optional 1.6 sec)
Start-up time *)	Less than 60 sec., measuring 30 min. full specification *) Refers to -20°C to + 45°C

DETECTOR WARNINGS

Early Dirty Optics	55% signal attenuation
Dirty Optics	70% signal attenuation
Detector failure	Main function fault or blocked optics.

OUTPUT SIGNAL

Standard	Current source 4 – 20 mA, max. load impedance 500 Ohm
Option	Current sink 4 – 20 mA
Maintenance	HART® interface

ELECTRICAL

Power supply	24 V DC, range 18-32 V DC
Power consumption	Approx. 3.5 W
Connection	3 wires (0.5mm ² - 1.5mm ²)
Cable entry	M20 Exe cable gland

TEMPERATURE RANGE

Storage	-40°C to + 70°C (-40°F to +158°F)
Operating	-40°C to + 65°C (-40°F to +149°F)
Humidity (operation)	100% RH

HOUSING

Main compartment	Exd IIC T6 Gb
Terminal comp.	Exe
Protection category	IP66/IP67 DIN 40050
Housing material	Stainless steel SIS2343 (ASTM 316)
Weight	Approx. 2.9 kg (6.4 Lbs)
Dimensions	264L x 104W x 106H (mm) 10.4 x 4.1 x 4.2 (inches)

WARRANTY

- 5 years full warranty on complete instrument
- 15 years warranty on the IR-sources

3. INSTALLATION



The area in which the detector may be installed must be in accordance with the certification of the detector and in accordance with the standards of the appropriate authority in the country concerned.

3.1. Positioning

The detector should be mounted where gas leakage is most likely to occur. To detect methane, which is lighter than air, inside an enclosed area the detector should be mounted high in the area to be protected or immediately above potential leakage sites.

To detect gases heavier than air, e.g. propane, the detector should be mounted below the potential leakage site.

The detector should be mounted in a place where maintenance, i.e. cleaning of the optics, is easily performed.

The detector may be mounted in areas where no oxygen is present.

The detector may be mounted in areas with strong airflow

The detector should NOT be mounted where it could be drenched by water.

3.2. Fixing

The detector is mounted by means of a projecting mounting leg using two M8 screws and washers, or by means of the Duct Mounting Flange Kit (4 x M8 screws).

The detector should be mounted so that the longitudinal axis of the detector is horizontal. This will prevent accumulation of water and dust on the optics. The Weather Protection must always be oriented correctly for optimal performance.

Weather Protection



Figure 3.1 GD10P mounted by means of mounting feet

3.3. Weather protection



When the GD10P is mounted outdoors, the flow direction indicator must point upwards.

See “Flow Direction Indicator” in Fig. 3.2 below. Orientation of the Weather Protection is performed as follows:

- Use a screwdriver to loosen the two screws on the Weather Protection
- Rotate the Weather Protection to correct position
- Tighten the screw with a torque of max. 0.5 Nm

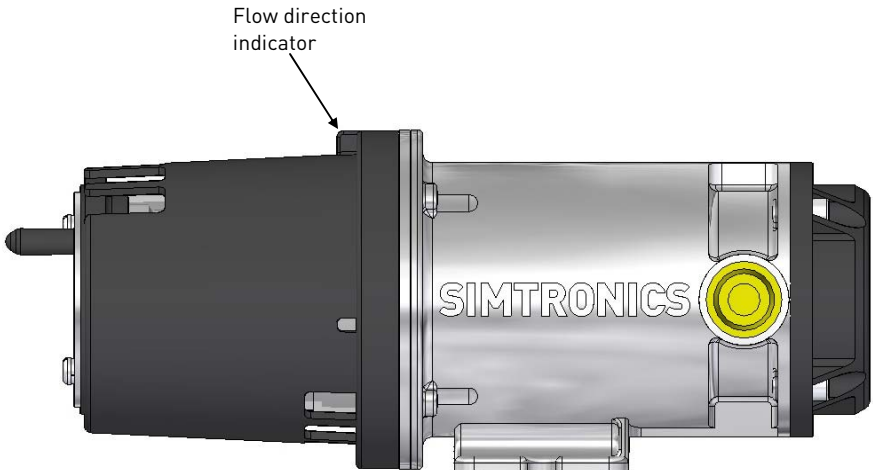

Figure 3.2 Orientation of GD10P weather housing in relation to flow direction

3.4. Duct or pipe mounting

If installed in a ventilation duct or pipe, the mounting arrangement and accessories shown in Figure 3.3 and 3.4 should be used.

The Duct Mounting Bracket shown in Fig. 3.3 allows the GD10P to be positioned in the core of the airflow in wide ducts or pipes.



Avoid direct light on lens and mirror if the GD10P is mounted without the Weather Protection.

In order to achieve minimum response time, the Weather Protection must be oriented with the flow direction indicator facing into the air flow. See Figure 3.2 and 3.4

The sensor must be mounted in straight parts of the duct with undisturbed airflow. Avoid areas with possible turbulent flow e.g. immediately after sharp bends or junctions.

The kit includes a modified weather protection as well as piping for functional testing.

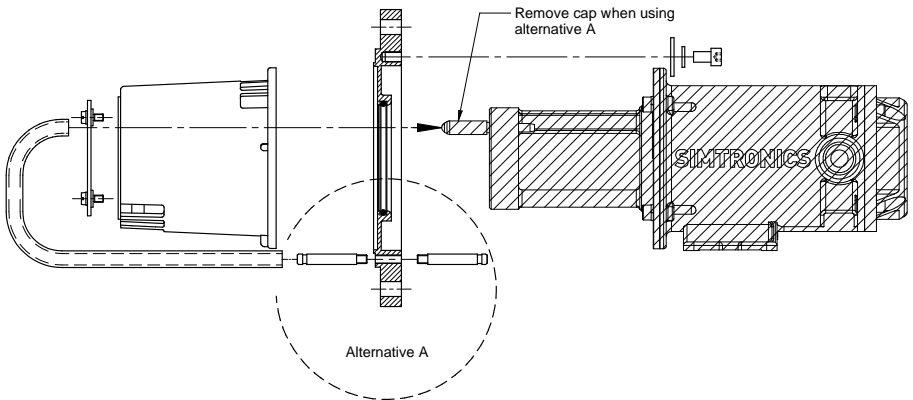

Figure 3.3 Exploded view, Duct Mount Flange Kit

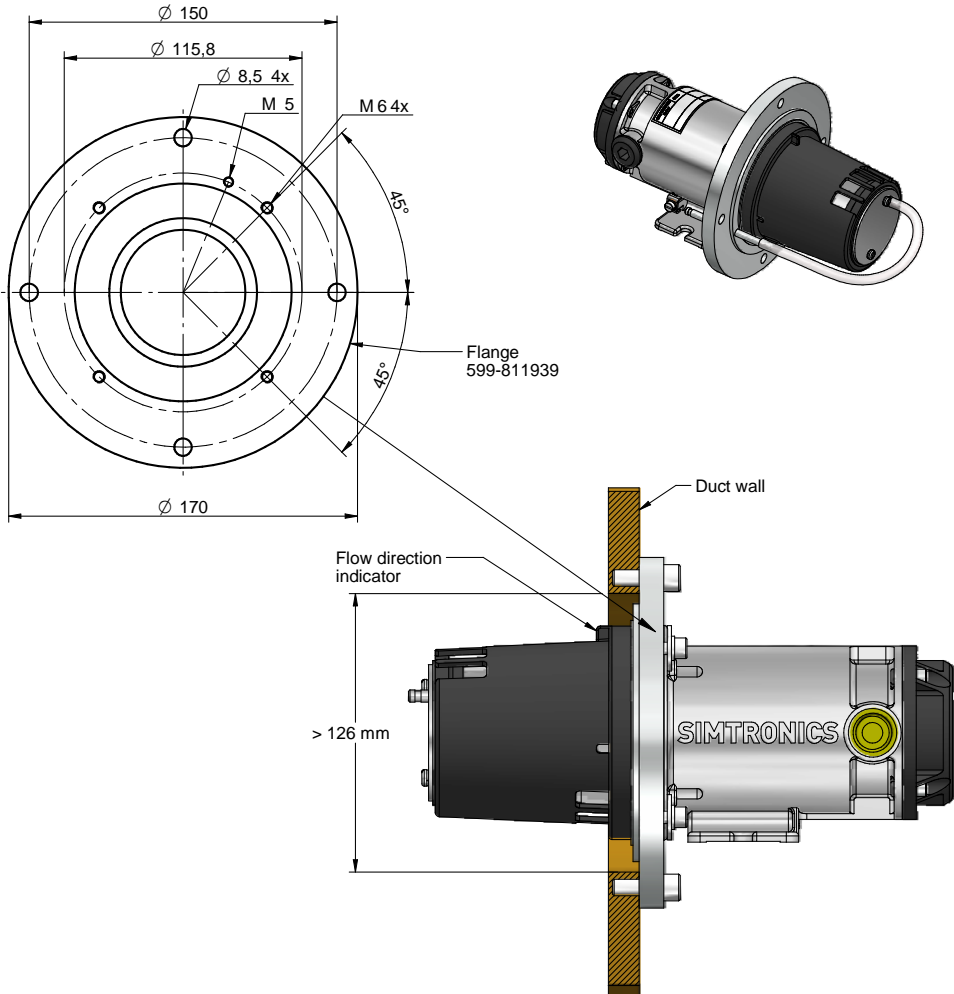

Figure 3.4 Ventilation duct or pipe mounting using Duct Mounting Flange Kit
Refer to: Figure 3.3 for details.

3.5. External cable

The cable type must be chosen in accordance with applicable regulations.

The table below indicates maximum cable lengths (2-wire) restrictions due to voltage drop over the power supply cable.

Single wire cross area	0,5 mm ²	0,9-1 mm ²	1,5 mm ²
Supply voltage 24VDC	250m	500m	750m

3.6. Electrical connection

The terminal compartment is accessible by removing the circular terminal cover. (Loosen the four M5 bolts).

The terminal compartment, including the terminals for electrical connection, is shown below.

The installation wiring enters the terminal compartment via a single M20 Exe cable gland, which can be mounted on either side of the compartment. The unused entry is blanked with an Exe cover.

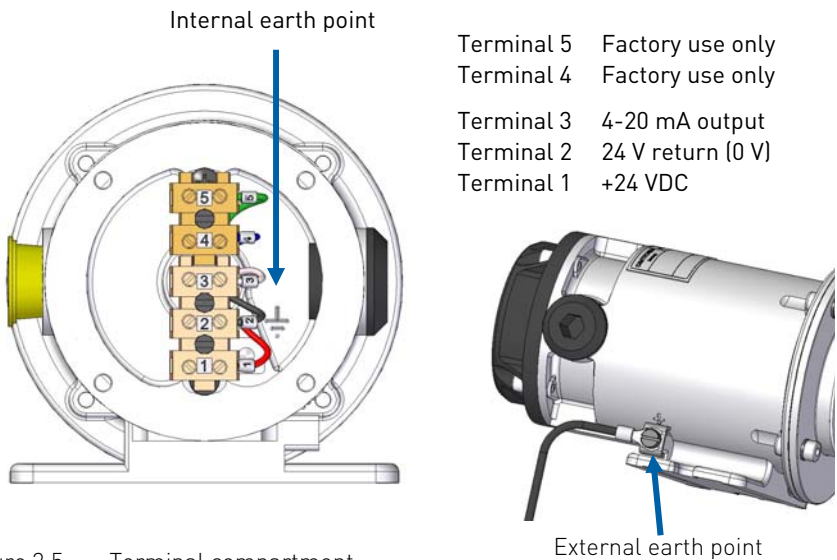

Figure 3.5 Terminal compartment

! The detector housing must be connected to local ground via the external earth point. The wire should be minimum 4 mm² (8 AWG) and as short as possible.

The shield of the cable should be connected to instrument earth in the central control module, and is normally not terminated at the detector. Exception: If extra RFI protection is required, and the installations grounding principles/regulations allows it, the shield is terminated to local ground via the internal earth point at the detector.

On UL variants, the terminal compartment is not used. Cables are instead led out of a bushing, and each cable termination is numbered as above.

4. COMMISSIONING

4.1. Visual inspection

The following should be checked before initial powering up:

- The axis of the detector shall be horizontal.
- Correct cable gland installation
- Electrical connection
- Electrical grounding
- Termination of cable shield
- Orientation of the weather protection
- All bolts and screws are tight

Please refer to the Installation chapter for details.

4.2. Power up

Ensure that system wiring and control system are in working order before powering the detector. The startup period takes about 60 seconds, a functional self-test is performed during this time. When the self-test is completed the detector turns over to measuring mode. The 4-20mA output will stay at 0mA during the 60 seconds startup period and 4mA (if no gas is present) in measuring mode. The graph on the left shows the reading of the 4-20mA analog output during startup period.

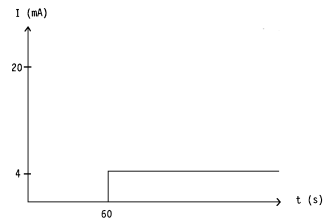

4.3. Checking system functions

The GD10P is factory calibrated, and does not require any adjustments before operation. A check prior to putting into service should however consist of:

1) Clean the optical surfaces

The detector may have been collecting dirt after being initially installed. It is thus crucial to clean the optical parts before testing the detector.

Please refer to: "6.1 Cleaning of optical lens/mirror".

2) Do a gas test

To make sure the detector works you should as a minimum do a function check as described in "6.2 Function test". Optionally you may do a full calibration test as described in "6.3 Calibration test".

5. OPERATION

5.1. Analogue Output Protocol

Gas reading and fault signalling is given through the 4-20mA current loop interface. The table below shows the analogue output level for the various conditions.

Condition	Analogue output	Comment
Normal gas reading	4 mA - 20 mA	4 mA = 0% of range 20 mA = 100% of range (or higher)
Early Dirty Optics Warning (55% signal reduction)	2 mA *]	Detector will still output gas concentration if it is greater than 7 % of range (FS)
Dirty Optics Warning (70% signal reduction)	1 mA *]	No detection
Detector Fault	< 0,5 mA *]	No detection

*] Shows default factory setting. Can be configured via HART® terminal

5.2. HART® Interface

5.2.1. Introduction

Simtronics GD10P detector supports HART® version 7.

For proper operation between GD10P and the HART® communicator, a dedicated Device Descriptor (DD) should be loaded onto the communicator. If such DD is not present, the communicator will offer a proprietary generic interface, and the list of available functions may be limited and variable.

The proper DD for GD10P can be downloaded from HART® Foundation website www.hartcomm.org (search for Simtronics under "Product Catalog" → "Wired Products", or requested directly from Simtronics. The loading of the DD onto a specific communicator must be done according to the relevant user guide for that communicator.



DD has no relevance for earlier versions of GD10 (the generic HART® devices). Customers having such detector still need to use #-codes described in Appendix 1 at page 30 of this manual.

5.2.2. Connection

For access to the detectors HART® features, connect an industry standard HART® communicator as shown in the following figures depending on the type of analogue interface [source or sink].

Note that for the HART® communication to work properly, a minimum loop resistance is required in the current loop. The actual value of the serial resistance in the diagrams below may vary depending on the rest of the resistance in the loop.

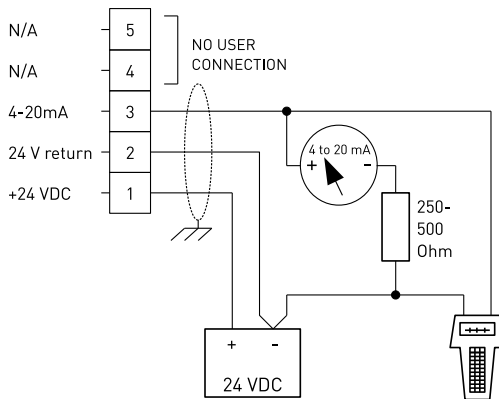

HART® terminal connection for source variant

H12001EN

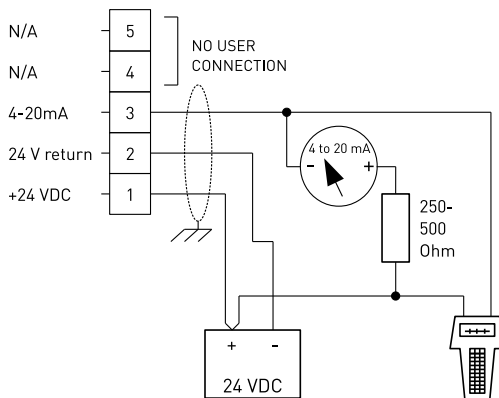

HART® terminal connection for sink variant

H12002EN

5.2.3. HART® Menu Map

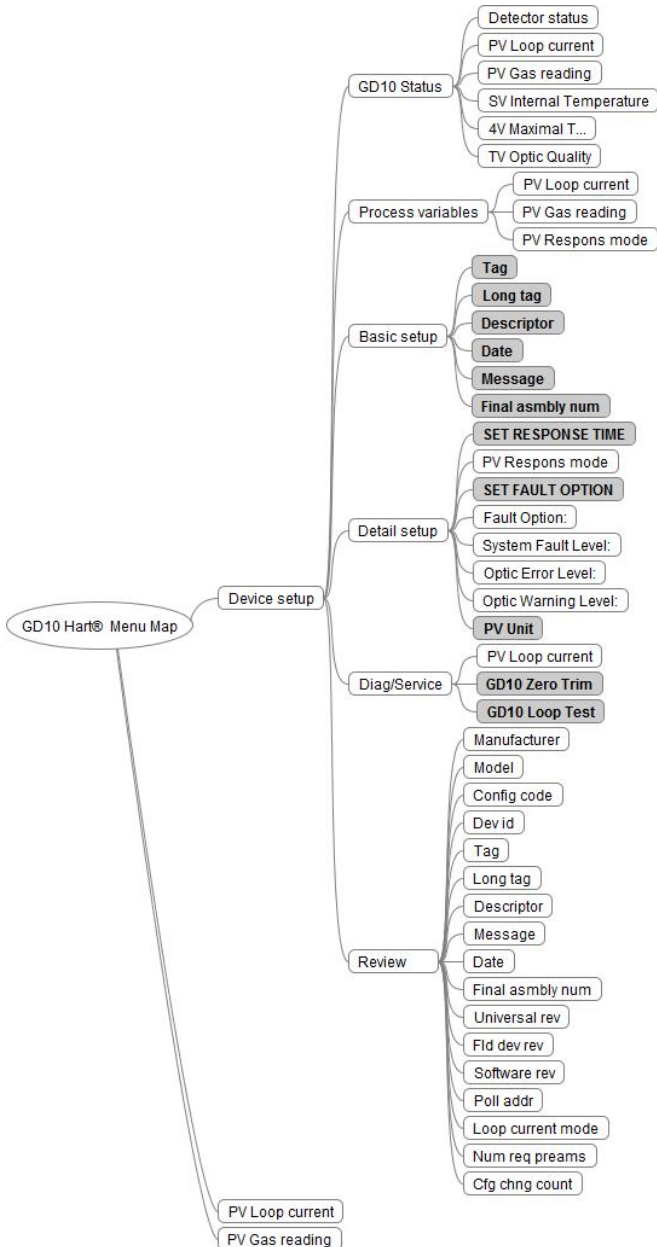

The menu map on the previous page, shows the complete list of available commands in the HART® interface of GD10. Most of the commands are only requests to read information from the detector. The commands shaded as grey with bold text gives the operator possibility to make changes to individual parameters, and these commands are described further in the following sections.

5.2.4. Detailed description of selected commands

When one of the following commands are activated, the operator is navigated to one or several data input screens where detailed data can be entered, or predefined options selected. Detailed navigation between the commands is not explained, as this is part of the user interface of the actual HART® communicator.

5.2.4.1. TAG (Basic setup)

The operator can write an alphanumeric text, max 8 characters. Default is "GD10".

5.2.4.2. Long tag (Basic setup)

The operator can write an alphanumeric text, max 32 characters. Default is empty.

5.2.4.3. Descriptor (Basic setup)

The operator can write an alphanumeric text, max 16 characters. Default is "SIMTRONICS A/S".

5.2.4.4. Date (Basic setup)

The operator can write a date on the format MM/DD/YY. Default is **/**/**.

5.2.4.5. Message (Basic setup)

The operator can write an alphanumeric text, max 32 characters. Default is "SIMTRONICS A/S".

5.2.4.6. Final asbly num (Basic setup)

The operator can write an alphanumeric text, max 8 characters. Default is "0".

5.2.4.7. SET RESPONSE TIME (Detailed setup)

The operator can choose between two response modes. Default is "5s".

5.2.4.8. SET FAULT OPTION (Detailed setup)

The operator can choose between three options according to the following table.

Option	Detector fault	Dirty Optics	Early Dirty Optics (see note 1)
OP0 (factory default)	<0.5mA	1mA	2mA
OP1	1mA	2mA	3mA
OP2 (User selectable)	1 (0 mA) 2 (1 mA) 3 (2 mA) 4 (3 mA)	1 (0 mA) 2 (1 mA) 3 (2 mA) 4 (3 mA)	1 (Don't care) 2 (1 mA + pulsing) 3 (2 mA) 4 (3 mA)

Note 1: If in “Early Dirty Optics” state, the detector will switch to standard output level when gas reading is >7% of detection range.

After a reconfiguration, it is recommended to restart the detector and verify the new settings by simulating different alarm/warning states. A current meter may be used to read the level at the analogue output.

5.2.4.9. PV unit (Detailed setup)

The operator can choose between several measurement units. Default is “%LEL”.

5.2.4.10. GD10 Zero Trim (Diag/Service)



This function should be activated by special trained operators. If zero trimming is not done in a controlled way, the performance of the detector can be reduced. Also, prior to launching this function, read the detailed descriptions in section 6.4.

When this function is activated, the operator gets on-line instructions on how to support the function. The analogue output will drop down to 1mA to indicate the on-going zeroing process, which takes about 3-4 minutes to complete. The analogue output returns to the actual zero (4mA) when zeroing process is completed. Zeroing will not take place if the ambient temperature is outside a specific temperature range (around 20 – 30 deg C). If the Zero level is not improved after the zeroing, the reason is that the zero drift is over the allowed limit for field trimming.

5.2.4.11. GD10 Loop Test (Diag/Service)

A fixed analogue output level can be used to test the analogue output loop. Such fixed analogue output level can be obtained with this function. The operator can choose one of the pre-set levels, or specify a user defined level.

6. MAINTENANCE



The GD10P has no user adjustable parts. It is not recommended to open the GD10P, as this will change the internal atmosphere, and the initial calibration could be affected. Opening the GD10P voids all warranty offered at the time of sale.

6.1. Cleaning of optical lens/mirror

Remove the weather protection by unscrewing the front cover plate (two screws), use a soft, clean tissue to rub off the contamination. The window and mirror are made of sapphire, which is highly resistant to scratching. Make sure that the whole optical surface is clean.



For difficult contaminants the mirror and lens can be cleaned with an equal-part mixture of isopropyl alcohol and water. Do not perform any testing of the detector before this solution has dried and residues have been wiped away.

6.2. Function test

In order to perform function test of the detector, a test gas can be applied through a 6 mm test nozzle on the front of the Weather Protection housing as the drawn shown below and observe the effect on the detector 4-20mA analog output or through the control system.

This is a simple test to verify the main function of the detector, please note the actual reading may be substantially lower than the calibration gas concentration due to leaks/ventilation of the weather protection. As long as the detector responds to the gas, the function of the detector is verified.

- 1) Clean the optical surfaces
- 2) Verify that the zero point (at no gas) is within the tolerance for the detector. Normal readings should be below 4.5mA
- 3) Apply gas as shown. If there is no air movement, a test gas flow of minimum four liters per minute will give approximately the same value as the test gas.

If there is an air movement of 0.5 m/sec., the test gas flow has to be increased (up to 20 liters per minute) to get a reasonable reading. Covering the ventilation grille will also help getting a



higher reading. However, you may not be able to reach the actual gas concentration, any reading above 10% is OK.

6.3. Calibration test



A calibration test is not required to verify the correct function of the detector. Normal maintenance testing of the detector is covered by the simple function test in section 6.2. The following calibration test is only applicable if it is required by regulations or in cases where you need to verify system performance during commissioning or similar thorough testing.

The GD10P detectors have a fixed calibration from the factory. A calibration test is thus just a test. There are no means to change the calibration on-site.

In order to perform calibration test, use a calibrated gas and apply it via a Sample Flow Housing (reg. no. 499-810874).

- 1) Remove the Weather Protection and clean the optical surfaces.
- 2) Attach the Sample Flow Housing. This is just press fit with two o-ring seals. Please note that the seals are not equally sized, so note the location of the test nozzle close to the detector housing.
- 3) Apply a certified test gas of approx. 50 % of GD10P calibrated range as shown in the drawing. The test gas should be the same as the target gas.

Gas flow should be approx. 1 liter/minute.

Wait approx. 2 min. to ensure that the Sample Flow Housing is completely filled with gas.

Read detector output or read output through the gas detection system. The reading should be within the tolerance of the detector plus the tolerance of the test gas. In practical terms this is the gas concentration +/- 10% of full scale.

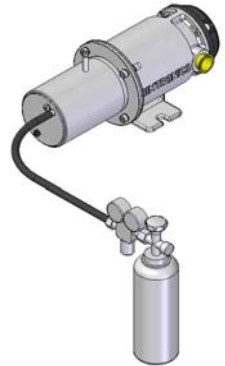

6.4. Re-zero



This maintenance activity should only be conducted by special trained operators. If this is not done in a controlled and proper way, the performance of the detector can be reduced. Simtronics has no responsibility for faults introduced by on-site re-zeroing.

The GD10 detector is calibrated and temperature tested in a controlled environment at the Simtronics factory. No further calibration is required during the life time of

the product, as the zero point and calibration will stay inside the given tolerances. This implies that slight offsets from the zero point of 4.0mA (0%LEL) is to be expected and values up to 4.5mA at room temperature are within specification.

In some environments with excessive heat and/or vibration we have noticed that a higher percentage of the detectors develop an offset outside the specified tolerances. These detectors should normally be returned to the factory for service. An alternative is to do this re-zeroing on site with a dedicated hand held terminal, or HART® communicator.



Note that “on site” does not mean “in service”. Before concluding that re-zero is necessary, proper cleaning of the detector should be done (even an invisible layer of oil on the lens or mirror can have negative impact on the zero-point reading). Then, before re-zeroing is conducted, the detector should be removed from the system and moved to a controlled environment in a workshop.

6.4.1. Test of zero-point in the workshop

Prior to conducting a re-zero, a controlled checking of the zero level should be done with a sample flow housing and nitrogen test gas (clean instrument air may be used if nitrogen is unavailable).

- 1) Clean the sensor optics again, both mirror and lens.
- 2) Attach a Sample Flow housing.
- 3) Connect the power supply and HART® terminal (according to section 0) or a Hand Held terminal according to its separate operating manual.
- 4) Switch on power and wait approx. 2 minutes until the output has stabilized.
- 5) Apply nitrogen gas to the Sample Flow housing.
- 6) Read current loop output.
- 7) If output is outside specification, then a re-zero may be applicable.

6.4.2. Re-zeroing with HART® communicator

See section 5.2.4.10.

6.4.3. Re-zeroing with Hand Held Terminal

Refer to the user guide of the Hand Held Terminal (850-816611).

6.5. Fault finding

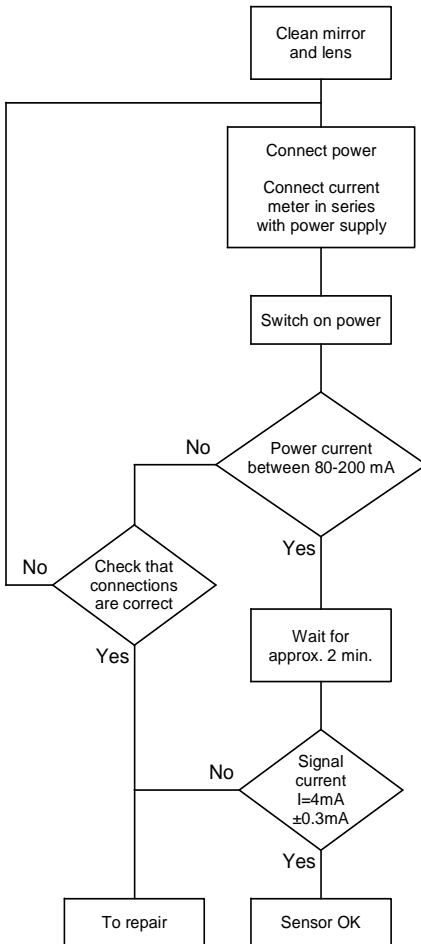

The internal microprocessor performs continuous self-testing of optical and electronic functions.

If a fatal error should occur in the electronics or optics, the processor will generate a 0mA output signal, indicating detector failure. The detector should then be checked according to flow chart on the left. Do not return the instrument to the supplier for repair if this test has not been performed.

If the IR transmission in the optical path is attenuated to 50-70% of its original value, the output signal will go down to Early Dirty Optics (warning).

If the IR transmission is further attenuated, the output signal will go down to Dirty Optics (fault). In this condition the detector will not detect gas.

If the optics is contaminated, wipe the optics with a clean cloth and mild detergent according to instructions in section. 6.1. The optics must be cleaned even if they appear not to be contaminated.



Avoid direct light on lens and mirror if testing without the Weather Protection.

Ensure that no gas is present in the measuring chamber when testing.

7. WARNINGS

This document is not contractual. The specifications may be modified without notice to improve the product, or to meet applicable standards.

7.1. Ownership and confidentiality

The information, design data, drawings and diagrams contained in this document remain the property of SIMTRONICS and are confidential.

The information contained in this document cannot be used, either partially or wholly, nor divulged or reproduced without the prior agreement of SIMTRONICS

7.2. Liability

The liability of SIMTRONICS shall be limited to any direct prejudice resulting from failure on SIMTRONICS part to fulfil the contract. SIMTRONICS shall decline all liability for any indirect prejudice caused.

By explicit agreement between the parties, the term “indirect prejudice” shall refer in particular to any financial loss, moral damage, loss of profit, earnings, clients or order, or any action taken against the client by a third party.

Moreover, any damages due from SIMTRONICS for any reason whatsoever shall not exceed the tax-exclusive value of the contract, except in the event of an intentional or fraudulent offence on the part of SIMTRONICS.

Application of the equipment warranty is subject to compliance with the state of the art and the operating instructions contained in this manual.

The SIMTRONICS warranty shall not apply, furthermore SIMTRONICS declines all liability, for damage to equipment or harmful accidents caused by negligence, failure to supervise the equipment or failure to use the equipment in compliance with the applicable recommendations, standards and regulations stipulated in the present manual.

The SIMTRONICS warranty shall not apply to faults resulting either, from materials supplied by the Purchaser, from design imposed by the Purchaser, from servicing or maintenance carried out on SIMTRONICS equipment by a third party not explicitly authorized, or from the use of unsuitable storage conditions.

8. WARRANTY

The GD10P comes with a 5 year warranty on the product. The warranty covers correct function inside specified tolerances. Faulty detectors under warranty will be repaired or replaced.

9. CERTIFICATIONS AND STANDARDS

9.1. Standards

The GD10P has been certified according to:

Atex Directive 94/9/EC

EMC Directive 89/336/EEC Article 4

MED Directive 86/89/EC amended by directive 2009/26/EC

Specific standards related to each directive and approval

9.2. Approvals



<u>Description</u>	<u>Simtronics reference</u>
Nemko, 07 ATEX1438	806-813901
Nemko, IECEx NEM 07.0006	806-816612
ABS, 04-OS495697-X	806-812498
INMETRO, TÜV 11.0314	806-816761
DnV, MED-B-5901	806-816800
UL, 092502-E219548	806-814172
CSA, 1773527	806-816248

(Note: HART® output is not evaluated for performance testing to Standard C22.2 No. 152.)

9.3. Marking

The GD10P identification labels are shown in the figures below. The composition of the label is in accordance with the relevant certification.

Atex Directive 94/9/EC, IEC Ex and INMETRO (Brasil) marking:

SIMTRONICS NO-0580 Oslo Norway		GD10	
	CE 0470	Nemko 07ATEX1438 IECEx NEM 07.0006	Input/Entrada: 18-32VDC, 0.3A, 3.5W Output/Saída: 4-20mA
		II 2 G Ex de IIC T6 Gb	
	Ex de IIC T6 Gb IP66/67 -40°C ≤ Ta ≤ +65°C		Warning: Understand manual before operating Atenção: Entenda o manual antes de operar
TÜV 11.0314		CF ID: Prod.Year / S.N.	

CSA marking for CO2 detection:

MC224046	GD10-		
	Ex de IIC T6 (Ta -40°C to +65°C)	Input rated 18-32VDC, 0.3A, 3.5W.	
		Output: 4-20mA	
Warning: Understand manual before operating	Reg.No	Prod.Year	S.No

CSA marking for combustible gas detection:

MC224046	GD10-		
	C22.2 No.152 Ex de IIC T6 (Ta -40°C to +65°C)	Input rated 18-32VDC, 0.3A, 3.5W.	
		Output: 4-20mA	
Warning: Understand manual before operating	Reg.No	Prod.Year	S.No

UL marking:

SIMTRONICS Norway	GD10		
	As to fire, electrical shock and explosion hazards only ITD2	Class 1 Div 1, Group C&D	
		Class 1 Zone 1, Group II B	
Reg.No		Prod.Year	S.No

UL CLASSIFIED FILE E219548 "CAUTION: TO REDUCE THE RISK OF HAZARDOUS ATMOSPHERES, DISCONNECT THE EQUIPMENT FROM THE SUPPLY CIRCUIT BEFORE OPENING. KEEP ASSEMBLY TIGHTLY CLOSED WHEN IN OPERATION" "MUST BE SUPPLIED FROM A CLASS 2 POWER SUPPLY" "CONDUIT SEALS MUST BE INSTALLED WITHIN 18" OF THE ENCLOSURE" Umax in = 32VDC Imax in = 0,15A

9.4. Explanation of product coding

GD10-P00-****-***-** (Code for detector only. See section 10 for accessories)



Gas calibration (a selection of most used variants)	
03DG	Ethylene, C ₂ H ₄ , 100 %LEL-1,
09DG	Propane, C ₃ H ₈ , 100 %LEL-1, 2.2%Vol
09EG	Propane, C ₃ H ₈ , 100 %LEL-2, 1.7%Vol
17BH	Methane, CH ₄ , 3 %Vol
17DG	Methane, CH ₄ , 100 %LEL-1, 5.0%Vol
17EG	Methane, CH ₄ , 100 %LEL-2, 4.4%Vol
18BG	Methane (Biogas), CH ₄ /CO ₂ , 100 %Vol
23AN	Carbon dioxide, CO ₂ , 10000 ppm
23BH	Carbon dioxide, CO ₂ , 3 %Vol
24BC	Carbon dioxide (Methane immune), CO ₂ , 5 %Vol
24BG	Carbon dioxide (Methane immune), CO ₂ , 100 %Vol
Not used	
0**	Fixed default value
Approval	
0	None
B	CSA
C	UL
X	ATEX/IECEx/INMETRO
Interface	
**H	4-20mA, source/HART®
**J	4-20mA, sink/HART®
Optional, future use	
00	Fixed default value

Example:

GD10-P00-17DG-0XH-00:

Methane, CH₄, 100 %LEL, ATEX/IEC Ex/INMETRO, 4-20mA, source/HART®

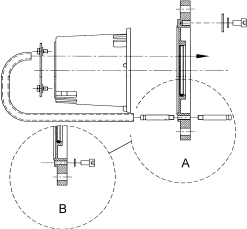
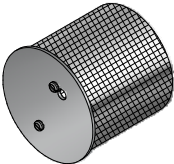
10. ACCESSORIES AND SPARE PARTS

Accessories	Description	Part Number
	<p>Sample Flow Housing Airtight chamber for sampling systems. Also used for calibration test.</p>	499-810874
	<p>Duct Flange Tube Kit GD10</p>	499-811938
	<p>Mosquito Set Assy GD10P Insect protection in stainless steel mesh. Slides on the outside of the standard weather protection.</p>	499-813397
	<p>Sun shade Assy GD10P For horizontal mounting</p>	499-815712
	<p>Sun shade for pipe mounting (horizontal or vertical pipe)</p>	599-816841

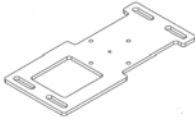

Pipe mounting plate
Including U-bolts

499-816867

Spare Parts	Description	Part Number
	Weather Protection Kit GD10	499-810913
	Cap, cover for the gas test nozzle.	599-904176
	Rear cover kit, composite	499-816584

APPENDIX 1 #-codes for generic HART® GD10

Current Gas reading

Read Primary Variable (command #1), returns the current gas reading.

Detector Variables

“Read all dynamic Variables and Current” (Command #3), returns the following:

- “Secondary Variable”: Current internal temperature of the detector
- “Tertiary Variable”: Current strength of the optical transmission path
- “Fourth Variable”: Maximum temperature the detector has been exposed to

Detector Information

Through standard HART® Universal commands (detailed user interface vary from one HART® terminal to another), specific information may be written to the detector and read back from the detector. Information supported: Tag (R/W), Descriptor (R/W), Message(R/W), Date (R/W) and Detector Serial number (R/W).

Configure Detector Response Time

“Write Damping Value” function (command #34) is used to configure the detector response time. “Damping Value” = 1 turns the detector to Fast mode (1 second response time) and “Damping Value” = 5 turns the detector to Normal mode (5 second response time).

Zeroing

“Set Primary Variable Zero” function (command #43) is used when trimming of the zero level of the gas detector is required. When the Set Primary Variable Zero is activated, the analogue output is dropped down to 1mA to indicate the on-going zeroing process, which takes about 3 minutes to complete. The analogue output returns to the actual zero (4mA) when zeroing process is completed. If the Zero level is not improved after the zeroing, the reason is that the zero drift is over the allowed limit for field trimming.

Fixed Output

A fixed analogue output level can be used to test the analogue output loop. Such fixed analogue output level can be obtained with the function “Enter/Exit Fixed Current Mode” (command #40). The possible level that may be fixed at the output is in the range (0.5-3) mA and (5.5-20) mA.

Configuration of the fault levels

Reconfiguration of the fault levels can be made by writing a Hash Code to the detector via the command "Write Message" (command #17). (The stored message is not changed by this action). After a reconfiguration, it is recommended to restart the detector and verify the new settings by simulating different alarm/warning states. A current meter may be used to read the level at the analogue output.

Hash Code:	Detector fault	Early Dirty Optics (see note 1)	Dirty Optics
#WFO0000 (factory default)	<0.5mA	2mA	1mA
#WFO1000	1mA	3mA	2mA
#WFO2X ₂ X ₃ X ₄	X ₂ =0 (0 mA) X ₂ =1 (1 mA) X ₂ =2 (2 mA) X ₂ =3 (3 mA)	X ₃ =0 (alarm off) X ₃ =1 (1 mA + pulsing) X ₃ =2 (2 mA) X ₃ =3 (3 mA)	X ₄ =0 (0 mA) X ₄ =1 (1 mA) X ₄ =2 (2 mA) X ₄ =3 (3 mA)

Note 1: If in "Early Dirty Optics" state, the detector will switch to standard output level when gas reading is >7% of detection range.

Note 2: The "0" in "#WFO", is the letter O, not the number 0.

CONTACT DETAILS

You will find an updated list of distributors on our web pages:

www.simtronics.eu

Email address for general enquiries: mail@simtronics.no

Simtronics AS
Kabelgaten 8, Økern Næringspark
PO Box 314, Økern, NO-0511 Oslo, Norway
Tel: +47 2264 5055

Simtronics SAS
792, av de la Fleuride
BP 11016, 13781 AUBAGNE CEDEX – FRANCE
Tel: +33 (0) 442 180 600

